

S5M AC Switch - disconnecter base mounting 6P - 8P

series
S5M

Size 0

A 125|160|200



	CODE - 125A	CODE - 160A	CODE - 200A
6P	S5M01256PS0	S5M01606PS0	S5M02006PS0
8P	S5M01258PS0	S5M01608PS0	S5M02008PS0

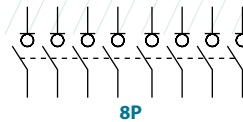
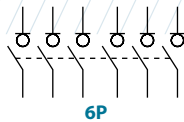

Technical information



According to IEC 60947-3

			125	160	200	
Rated thermal current in ambient at	Ith	40 °C	A	125	160	200
		50 °C	A	125	160	200
		60 °C	A	125	160	200
Rated insulation voltage	Ui	V	1000	1000	1000	
Rated impulse withstand voltage	Uimp	kV	8	8	8	
AC rated operational current ^{*(1)} (Rated operational frequency 50/60 Hz)	Ie	Ue 400V AC21A	A	125	160	200
		Ue 400V AC22A	A	125	160	200
		Ue 400V AC23A	A	125	160	160
Rated breaking capacity	400V AC23	A	1000	1280	1280	
Rated making capacity	400V AC23	A	1250	1600	1600	

^{*(1)} Other voltages and / or utilization categories. Please consult

^{*(2)} Without limiting protective device (short-circuit maintained 50... 100 ms.)

			125	160	200
Short - circuit behaviour					
Rated short-circuit making capacity ^{*(2)}	Icm kA (peak)		13	13	13
Rated short-time withstand current (1sec.)	Icw kA rms		7	7	7
Mechanical features					
Number of mechanical operations (according to the standards, for other values please consult)	Cycles		8000	8000	8000
Maximum weight 6P	Kg		1,8	1,8	1,9
Maximum weight 8P	Kg		2,1	2,1	2,2

Accessories



» Direct handle

CODE DS-SI01

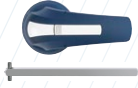

» External handle included shaft^{*(e1)}

IP65
CODE DS-LA01



» Emergency external handle included shaft^{*(e1)}

IP65
CODE DS-LR01

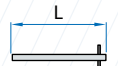

» Shafts

Standard shaft included^{*(e1)}

L (mm)	P (mm)
177	155... 263

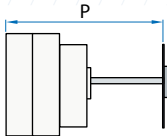

» Auxiliary contacts

1NO+1NC CODE DS-AU11
2NO+2NC CODE DS-AU12

Ie = 16 A (resistive loads)
4 A (inductive loads) at 250 Vac.



» Terminal shrouds^{*(T)}

	UP 6P (1 unit)	DOWN 6P (1 unit)	UP OR DOWN 8P (1 unit)
	DS-CU02	DS-CU03	DS-CU04
	DS-CU05	DS-CU06	DS-CU07

(For frontal switch only)



» Phase barrier^{*(T)}

	6P	8P
	DS-PB01	DS-PB02
	DS-PB04	DS-PB03

(1 kit for input or output)

^{*(T)} These accessories aren't compatible with each other.



» Safety key lock devices

Simple CODE DS-CAB1
Double CODE DS-CEB1

For external handle, lock the handle by means of a key in position "OFF" (under request, in "ON"), the key can only be removed with the handle locked

Door drilling for handle and key lock device
Simple Double

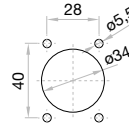
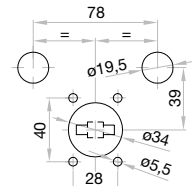
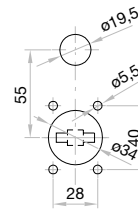

Door drilling for external handle

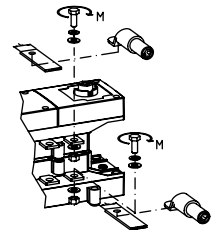

Dimensions (mm)

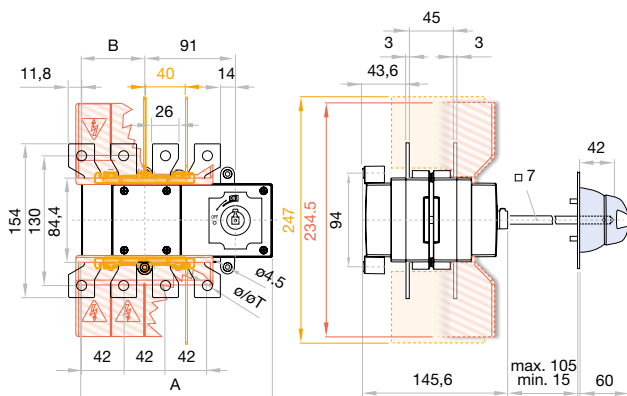
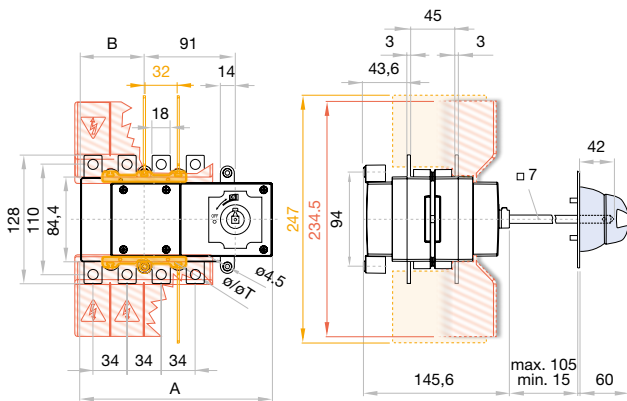

	A		B		ø	S max (Cu)	H max (Cu)	L max (Cu)	M	M
	6P	8P	6P	8P						
125 A	181	192	53	64	10	95	5	25	M8	13
160 A										

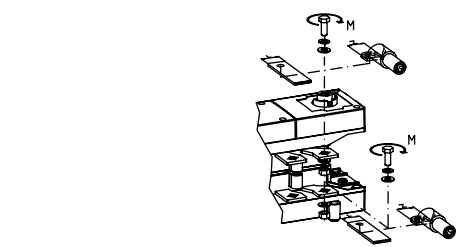

	A		B		ø	S max (Cu)	Z max	H max (Cu)	L max (Cu)	M	M
	6P	8P	6P	8P							
200 A	181	192	53	64	10	120	30	5	30	M10	18